

# Ritchie Specs

## JLG 2646ES Scissor Lift

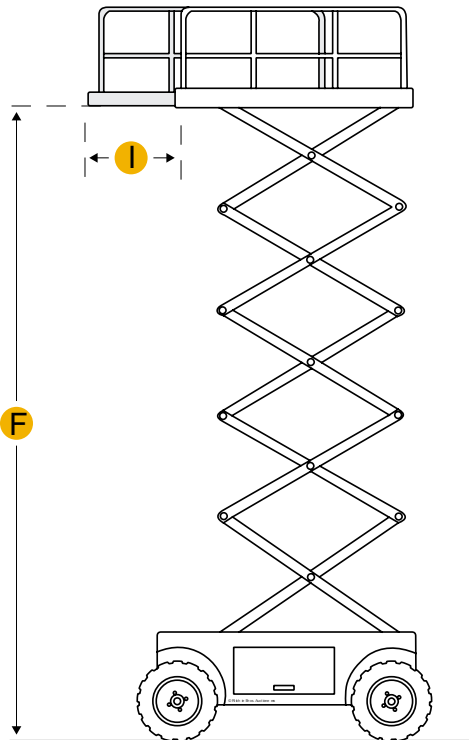
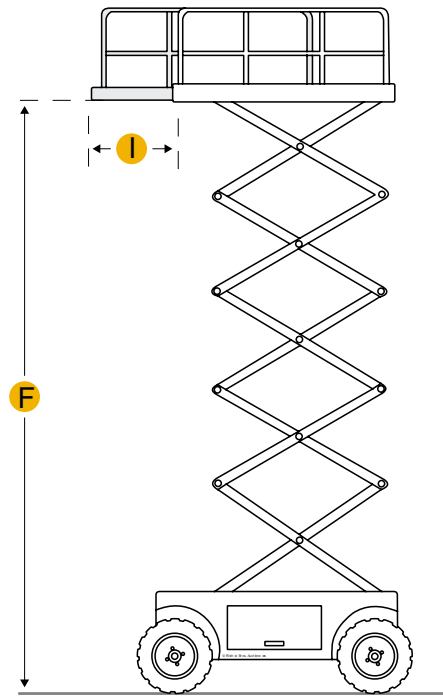
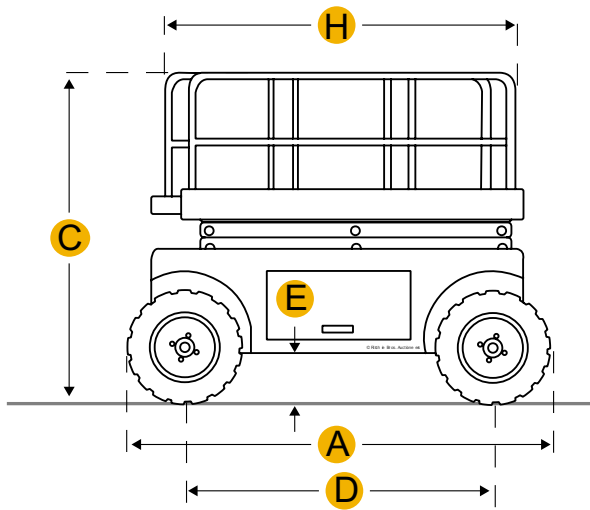

# Dimensions

## Dimensions

<b>A Overall Length</b>	100 in
<b>D Wheelbase</b>	6.1 ft in
<b>B Overall Width</b>	3.84 ft in
<b>C Height W/ Rails</b>	78 ft in
<b>E Ground Clearance</b>	5 in
<b>Platform Dimension B</b>	3.8 ft in
<b>Platform Dimension A</b>	8.31 ft in
<b>Overall Height</b>	7.9 ft in
<b>Height W/O Rails</b>	6.47 ft in
<b>Turning Radius</b>	7.11 ft in

## Platform

<b>F</b> Max Platform Height	25.99 ft in
<b>I</b> Deck Extension	35.44 in
<b>J</b> Height Of Rails	3.61 ft in
Platform Capacity - Extension	250 lb
Platform Capacity - Unrestricted	1000 lb
Max Platform Weight Capacity	1000.9 lb
Lower Time	50 sec
Max Working Height	32 ft in
Platform Inner Width	44.1 in
Platform Railing Height	25.99 ft in
Lift Time	41 sec
Platform Inner Length	98.43 in

## Specifications

### Engine

<b>Maximum Ground Bearing Pressure</b>	87 psi
<b>System Voltage</b>	24 V
<b>Number Of Batteries</b>	4
<b>Battery Amp Hours</b>	200
<b>Charger Amps</b>	20 amps

### Operational

<b>Operating Weight</b>	4768.6 lb
<b>Hydraulic System Fluid Capacity</b>	1.7 gal
<b>Max Speed</b>	2.5 mph
<b>Tire Size</b>	16x5 in
<b>Tire Fill/Type</b>	Solid, Non-marking
<b>Hydraulic Pump Type</b>	Fixed Displacement Gear

### Performance

<b>Drive Speed - Platform Elevated</b>	0.5 mph
<b>Drive Speed - Platform Lowered</b>	2.5 mph
<b>Maximum Drive Height</b>	26 ft in
<b>Maximum Lift Height</b>	26 ft in
<b>Gradeability</b>	25 %

### Brakes

<b>Brakes Type</b>	Electric, Friction
--------------------	--------------------

## Compare similar models

<b>Manufacturer/Model</b>	<b>Max Platform Weight Capacity</b>	<b>Max Working Height</b>	<b>Operating Weight</b>
<a href="#">JLG 2632ES</a>	--	31.6 ft in	4635 lb
<a href="#">JLG 3246ES</a>	1000.9 lb	--	4779.7 lb
<a href="#">Snorkel S2646</a>	1000.9 lb	--	5147.8 lb

